

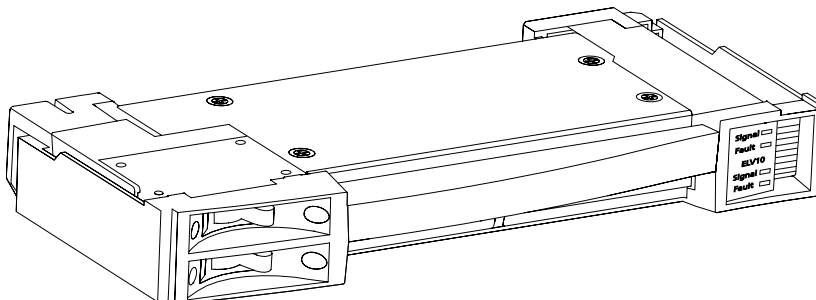

100V 120V

Special Purpose Series



GENERAL INFORMATION

The Electronic Reverse Phase Control Dimmer Module is a dual, plug-in dimmer for use in the Unison Dimming Series rack enclosures. The Electronic Reverse Phase Control Module provides cost effective, reverse phase angle dimming, of electronic transformer circuits. The design features high-density modular assembly, fully magnetic and fully rated circuit breakers, and electronic low-end set controls via control module.

APPLICATIONS

- Designed for use in 100-120V Unison DRd rack enclosures
- Electronic low voltage transformers
- Electronic LED power supplies requiring reverse phase control

FEATURES

- Two 1.2kW dimmers per module
- High-density modular assembly
- Die-cast aluminum chassis
- Fully magnetic circuit breaker
- Electronic low-end set controls

GENERAL

- 100,000A Short Circuit Current Rating (SCCR)
- UL and cUL LISTED

ORDERING INFORMATION

100-120 Volt Electronic Reverse Phase Modules

MODEL	DESCRIPTION
ELV10	Dual 10A Electronic Reverse Phase Module

Compatible Systems

MODEL	DESCRIPTION
DRd6-12-120	100-120V 6 module rack enclosure (12 circuits)
DRd12-24-120	100-120V 12 module rack enclosure (24 circuits)

*Rack enclosures also available for 240 and 277 Volt applications

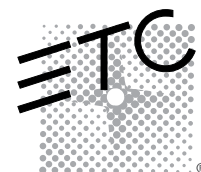

SPECIFICATIONS

GENERAL

- Dual density, plug in modules, for use in Unison Dimming Series rack enclosures
- Provides Reverse Phase Control dimming for electronic low-voltage transformers
- UL and cUL Listed for continuous duty at 100% of rated load - ELV10 – 1.2kW

PHYSICAL

- Modular plug-in assemblies
- Cast aluminum chassis, finished with textured epoxy paint

CIRCUIT BREAKERS

- Fully magnetic to eliminate nuisance tripping
- 20x inrush current rating
- 125%, 10-120 seconds, must-trip rating
- Rated for 100% switching duty applications

ELECTRICAL RATINGS

- 100,000A Short Circuit Current Rating (SCCR)
- UL and cUL LISTED

POWER DEVICE

- One control and one output LED per circuit
- 4000V isolation between control and power components
- Integral temperature sensor

EFFICIENCY

- Efficiency is 96.9%

OPERATION MODES

FORWARD PHASE FIRING MODE

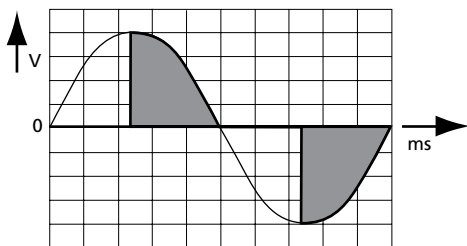

REVERSE PHASE FIRING MODE

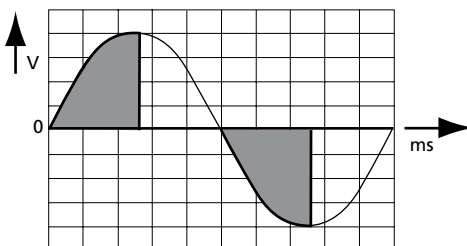

PHYSICAL

Module Dimensions

MODEL	HEIGHT		WIDTH		DEPTH	
	inches	mm	inches	mm	inches	mm
ELV10	1.5	38.	11.8	300	4.9	127

Module Weights

MODEL	WEIGHT		SHIPPING WEIGHT	
	lbs	kgs	lbs	kgs
ELV10	2.4	1.1	3.3	1.5

Maximum BTU Production per module

MODEL	BTUS	WATTS	EFFICIENCY
ELV10	286.8	84	96.5%

These values should be provided to a qualified HVAC design engineer, along with dimmer quantities, types and dimmer room dimensions, to calculate dimmer room air handling requirements.

Dimmer room HVAC systems must at all times maintain the specified ambient temperature **at the dimmer rack**. Dimming systems operating within 10°F of the upper or lower temperature limits must strictly follow installation and operation guidelines to operate reliably.

